

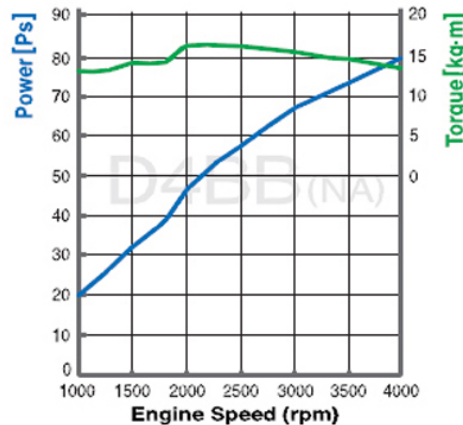

DIESEL FOR WATER PUMP



DESCRIPTION		D4BB(59KW/80PS/4,000RPM)
DISPLACEMENT(cc)		2,607
BORE X STROKE(mm)		91.1X100
MAX. POWER (ps/rpm)		80/4,000
MAX. TORQUE (kg.m/rpm)		17/2,200
DIMENSION (mm)	LENGTH	710
	WIDTH	673.4
	HEIGHT	641
WEIGHT IN DRY(kg)		200.8
CYCLE		4
NO. OF CYLINDER		4
CYLINDER ARRANGEMENT		IN-LINE
FIRING ORDER		1-3-4-2
COMPRESSION RATIO		22
ASPIRATION		NA
ALTERNATOR(V-A)		12-75
STARTER MOTOR(V-kw)		12-2.0
BSM(balance shaft module)		IN BLOCK
ETC(electronic throttle control)		Non
TIMING TRAIN		BELT

Pump Performance Curve

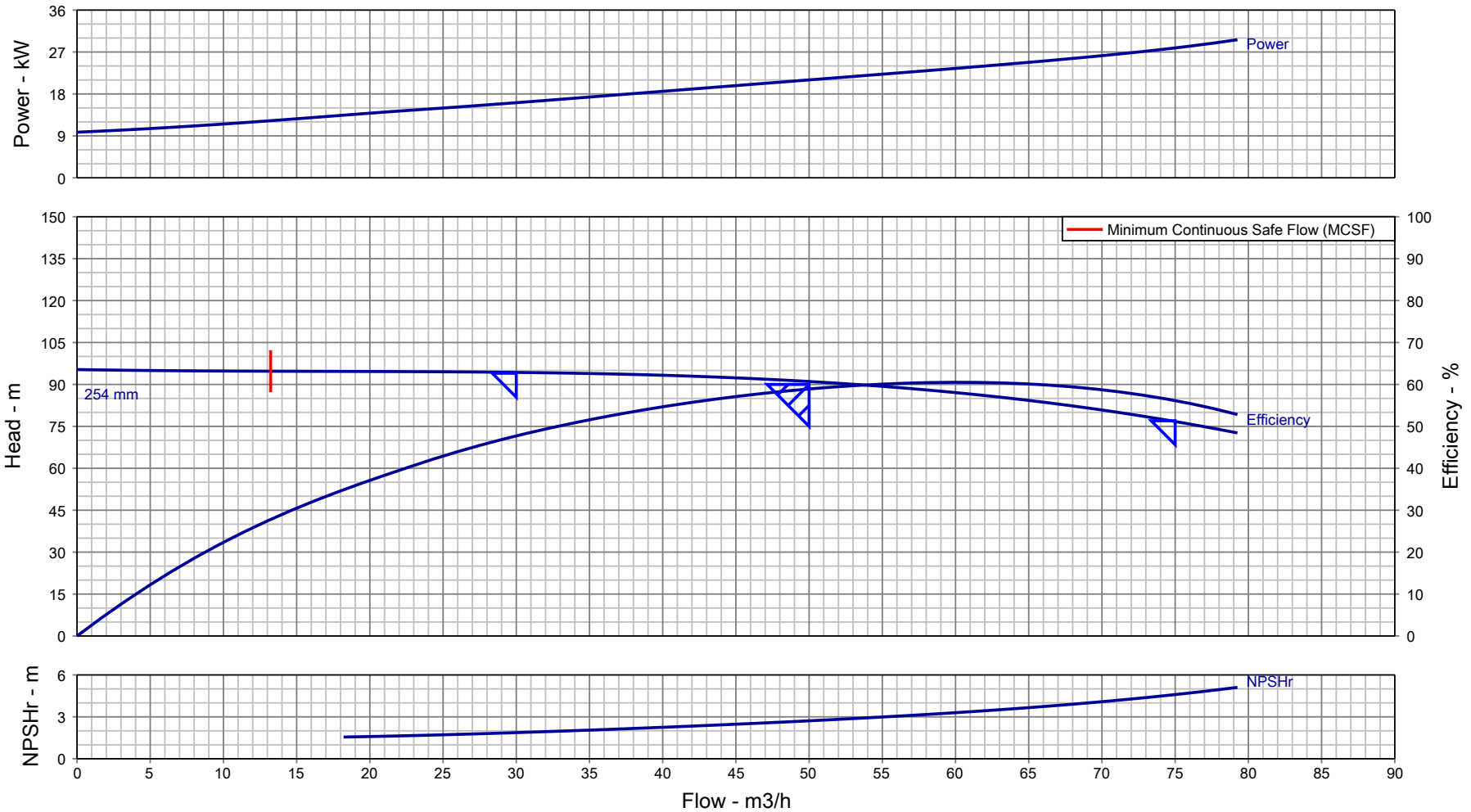

Customer :	Pump Size/ Stages : DB 50/26/ 1	Flow, rated : 50.00 m ³ /h
Customer enquiry :	Speed, rated : 2950 rpm	Differential Head : 90.00 m
Project : Default	Based on curve number : HD10212A0 Rev 0	Fluid density rated : 0.998 kg/dm ³
Quote number : 312657	Viscosity : 1.00 cSt	Efficiency : 58.92 %
Item number : 001	Cq/Ch/Ce/Cn [HI2010] : 1.00 / 1.00 / 1.00 / 1.00	Power, rated : 21.01 kW
Quantity : 1	Minimum recommended driver rating : 30.00 kW / 40.23 hp	NPSH required : 2.72 m
Date last saved : 08 Oct 2020 11:53 AM	Performance testing standard : ISO 9906 / ANSI-HI 14.6 Gr 2B	Liquid Type/ Application : Water

Notes: 1. Performance at shut off condition is approximate. 2. Rated impeller diameter is approximate. 3. Only duty point is guaranteed as per testing standard.



Enriching Lives

Pump Performance Datasheet			
General			
Customer	:	Quote number	: 312657
Customer Enquiry No.	:	Pump model	: DB 50/26
Project	: Default	Stages	: 1
End user	: -	Based on curve number	: HD10212A0 Rev 0
Tag number	: 001	Date last updated	: 08 Oct 2020 11:53 AM
Service	: -	Quantity of pumps	: 1
Operating Conditions		Liquid	
Flow, rated	: 50.00 m3/h	Liquid handled	: Water
Suction pressure, rated / max	: 0.00 bar.g / 0.00 bar.g	Additional liquid description	: Fresh Water
Discharge pressure, rated	: 8.91 bar.g	Temperature, max	: 20.00 deg C
Head, rated (requested)	: 90.00 m	Solids diameter, max	: 0.00 mm
NPSH available, rated	: Value not specified	Solids in suspension by volume	: 0.00 %
Frequency	: 50 Hz	Specific gravity, rated / max	: 0.998 / 0.998 kg/dm3
Performance		Viscosity, Rated / Max.	: 1.00 cSt / -
Pump speed, rated	: 2950 rpm	Driver & Power Data	
Impeller Dia, Rated (Approx.)	: 254 mm	Driver sizing specification	: Maximum Power
Impeller diameter, maximum	: 264 mm	Margin over specification	: 0.00 %
Impeller diameter, minimum	: 205 mm	Power, rated	: 21.01 kW
Efficiency at duty point	: 58.92 %	-	: -
NPSH required / margin required	: 2.72 m / 0.50 m	-	: -
MCSF	: 13.22 m3/h	Driver Rating	: 30KW
Cq/Ch/Ce: [-]	: 1.00 / 1.00 / 1.00	Pressure Data	
Water eq. duties (Qw/Hw/Ew)	: 50.00 m3/h / 90.00 m / 58.92 %	Maximum working pressure	: 9.33 bar.g
Suction / Delivery nozzle size	: 65.00 mm / 50.00 mm	Maximum allowable working pressure	: 16.00 bar.g
Noise level	: 90 dB	Maximum allowable suction pressure	: 1.96 bar.g
Vibration level (RMS)	: 5.1 mm/s	Hydrostatic test pressure	: 18.34 bar.g
Test standard	: ISO 9906 / ANSI-HI 14.6 Gr 2B	Construction	
Starting condition	: Closed Delivery Valve	Basic construction	: End Suction Pump-OH1
Material		Impeller type	: Enclosed
MOC Code	: 16MOC	Selection status	: Acceptable
Material (Casing / Impeller / Shaft)	: CI IS210:FG260 (012) / CI IS210:FG260 (012) / ST ST ASTM A276-410 ANLD (253)	Rec. Pipe Size (Suc / Del)	: 100 mm / 100 mm
-	: -		

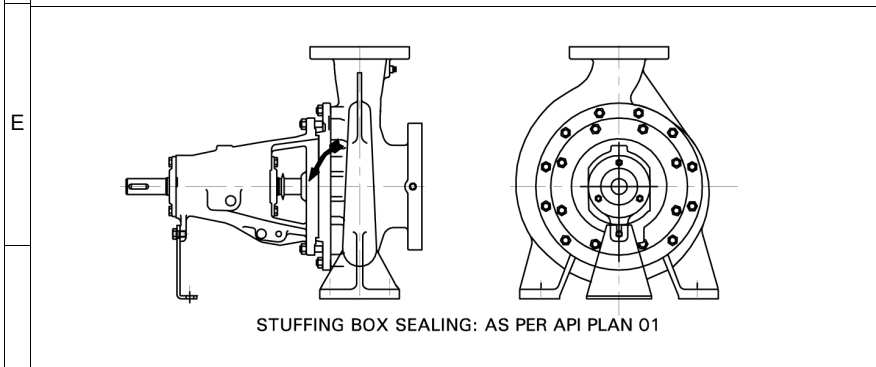
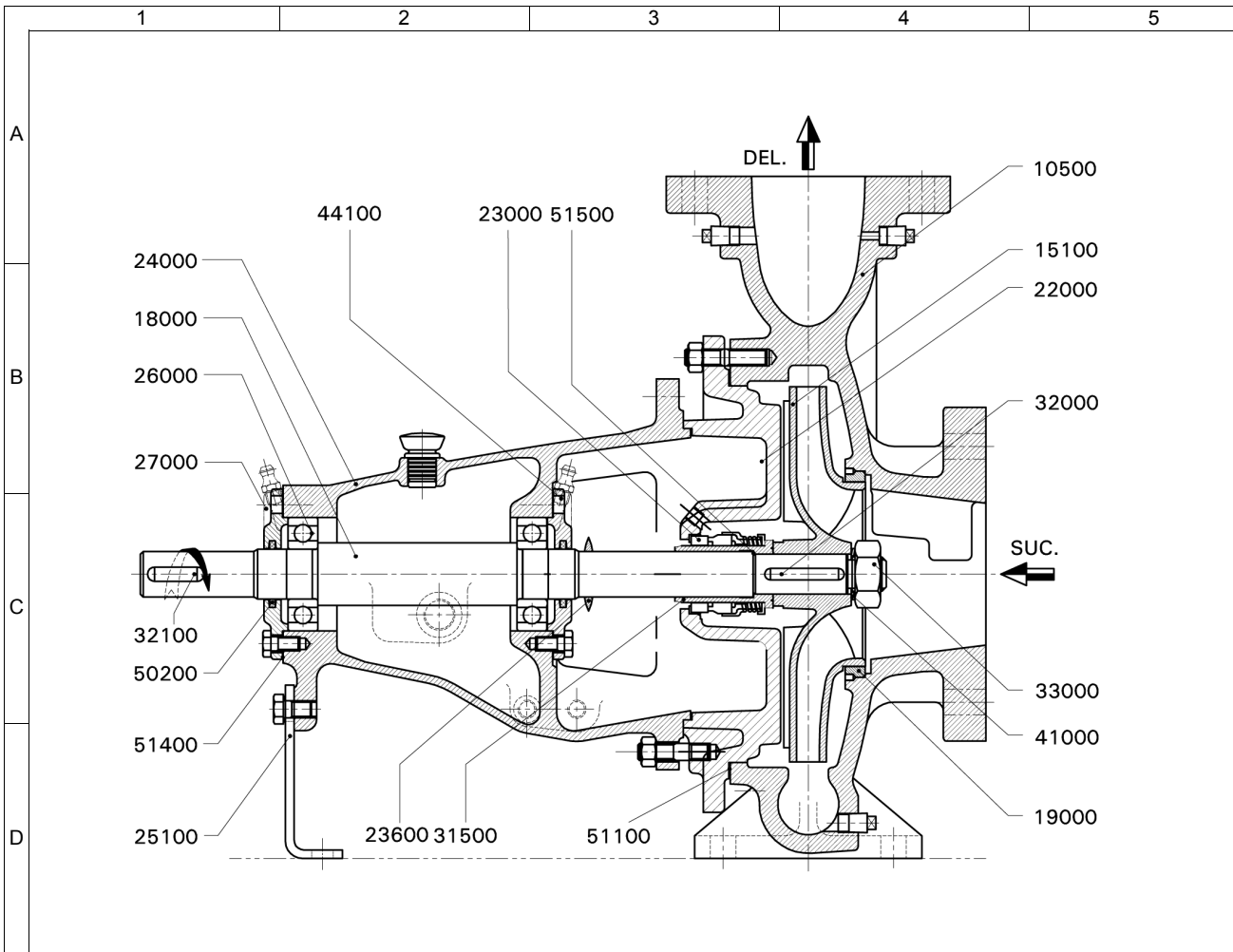

NOTES:
 • " * " INDICATES RECOMMENDED SPARES.
 • FASTENERS IN LIQUID CONTACT ARE IN CS

IMPORTANT: THIS DRAWING IS THE PROPERTY OF Kirloskar Brothers Limited. AND MUST NOT BE USED OR COPIED WITHOUT THEIR PRIOR AUTHORITY IN WRITING.



Enriching Lives

PART NO.	PART DESCRIPTION	MAT. CODE	MOC DESCRIPTION
10500	PUMP CASING	012	CI IS210:FG260
15100*	IMPELLER	012	CI IS210:FG260
18000*	PUMP SHAFT	253	ST ST ASTM A276-410 ANLD
19000*	WEAR RING - SUCTION SIDE	012	CI IS210:FG260
22000	CASING COVER	012	CI IS210:FG260
23000*	MECHANICAL SEAL	998	DIN SEAL
23600*	LIQUID DEFELCTOR	370	NATURAL RUB ASTM D2000AA-70SHORE/7MPa
24000	BEARING HOUSING	012	CI IS210:FG260
25100	SUPPORT FOOT	042	MS IS:5986-Fe410WA (OLD-IS:1079)
26000*	DEEP GROOVE BALL BEARING	000	STEEL
27000	BEARING COVER DE & NDE	012	CI IS 210-FG 260
31500*	SHAFT SLEEVE - MECHANICALSEAL	565	ST ST ASTMA276-410(210/250BHN)-ANLD
32000*	KEY FOR IMPELLER	253	ST ST ASTM A276-410 ANLD
32100	KEY FOR COUPLING	053	CS IS1570:40C8 HOT RLD
33001*	IMPELLER NUT	664	AUS ST ASTMA194/194M-8M-UNS S31600 (NUT)
41000*	LOCK WASHER-IMPELLER NUT	054	SPRING ST IS:4072-80C6
44100	GREASE NIPPLE	444	CS IS:1367 Part3 CL4.6 CDP
50200*	FELT RING	375	FELT
51100*	GASKET-CASING COVER	702	NON ASBESTOS FERROLITE NAM37 OR EQ
51400*	GASKET-BEARING COVER	702	NON ASBESTOS FERROLITE NAM37 OR EQ
51500*	GASKET-SHAFT SLEEVE	702	NON ASBESTOS FERROLITE NAM37 OR EQ

PUMP	DB 50/26	MOC	16
ENQUIRY NO./DATE	/	QUANTITY	1
PO. NO./DATE	-	TAG NO.	001
QUOTATION NO.	0	DATE.	-
O/A. NO.	-	MISI.	-
CUSTOMER	-		
END USER	-		
PROJECT	Default		
CONSULTANT	-		
SERVICE	-		

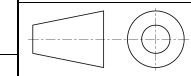

Kirloskar Brothers Limited
 KIRLOS KARVADI - 416308, DIST.- SANGLI (INDIA)

CROSS SECTIONAL DRAWING

DRAWING NO.	TC02-1
-------------	--------

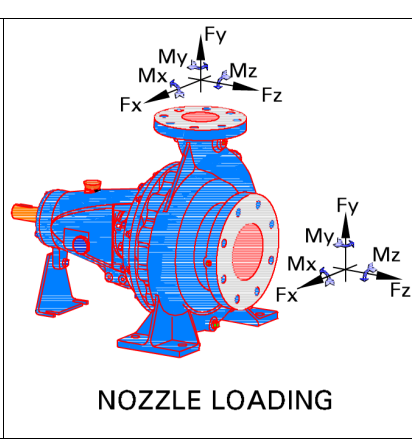
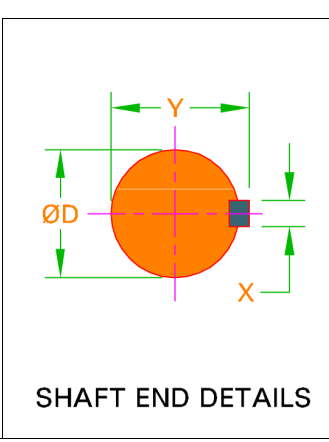
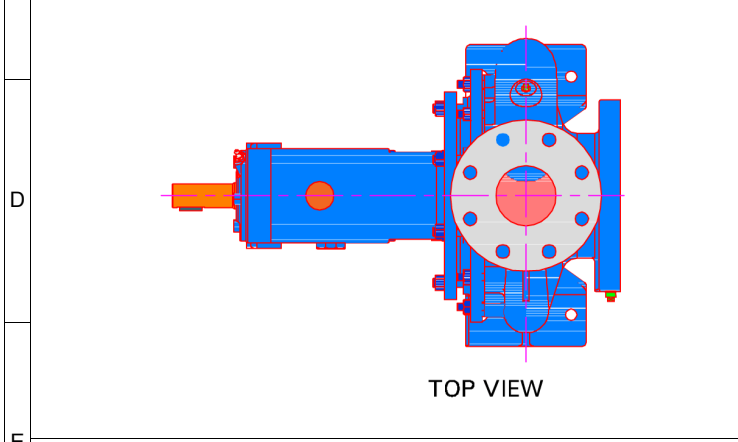
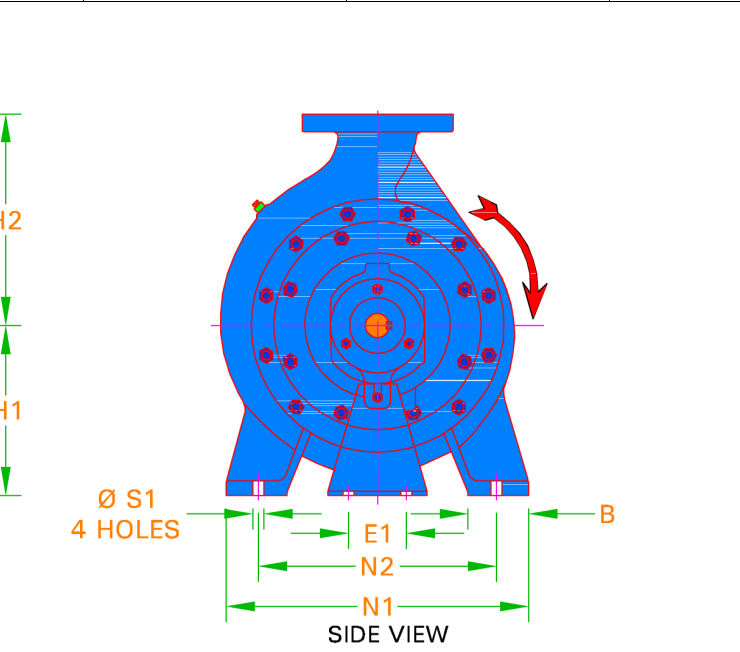
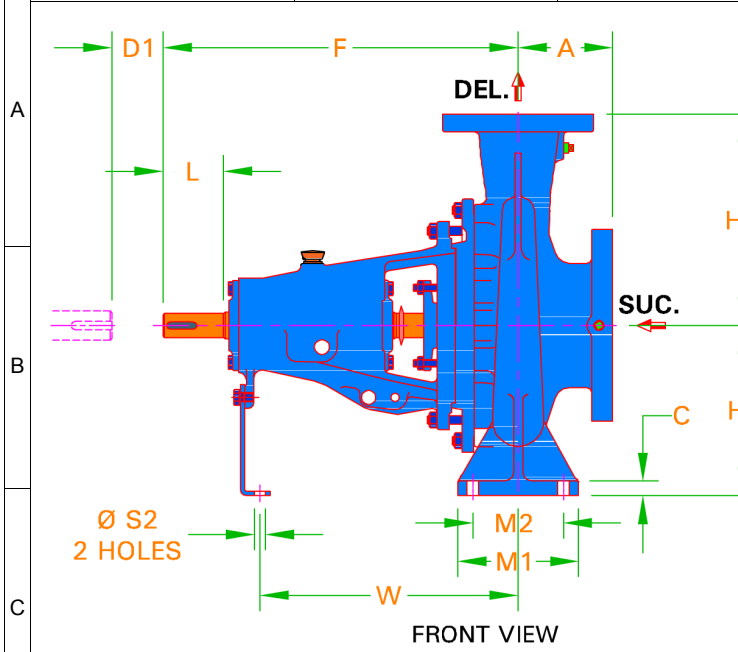

Enriching Lives

PUMP DUTIES			
CAPACITY	50.00 m ³ /h	EFFICIENCY	58.92 %
TOTAL HEAD	90.00 m	PUMP INPUT	21.01 kW
DENSITY	0.998 kg/dm ³	NPSHR	2.72 m

FLANGE DRILLING STANDARD AND DETAILS					
SUCTION	BS EN1092 PN16 FF	DELIVERY	BS EN1092 PN16		
	NOM. SIZE	RF DIA.	P.C.D.	NO OF HOLES	HOLE DIA.
SUCTION	65.00 mm	N.A.	145 mm	4	18.0
DELIVERY	50.00 mm	N.A.	125 mm	4	18.0

ALLOWABLE NOZZLE LOADING						
	FORCES			MOMENTS		
	Fx	Fy	Fz	Mx	My	Mz
SUCTION	57.00 kgf	142.0 kgf	114.0 kgf	843 N.m	422 N.m	422 N.m
DELIVERY	45.00 kgf	114.0 kgf	91.00 kgf	677 N.m	343 N.m	343 N.m

TAPPING DETAILS	
DESCRIPTION	SIZE / TYPE
Suction Gauge	1/4"BSP
Delivery Gauge	1/4"BSP
Casing Drain	3/8"BSP
Casing Vent	NA
Bearing Cooling in / out	NA
Pad Cooling in / out	NA
Priming in	NA
Base Drain	NA

DIRECTION OF ROTATION FROM DE CLOCKWISE

PUMP	DB 50/26	PUMP WT.	63.00
		GD*2	0.02 kg
REC. DRIVER RATING	30KW	RATED SPEED	2950R
ENQ. NO./DATE	/	QUANTITY	1
PO. NO./DATE	-	TAG NO.	001
QUOTATION NO.	0	DATE	-
O/A NO.	-	MISI	-
CUSTOMER	-		
END USER	-		
PROJECT	Default		
CONSULTANT	-		
SERVICE	-		

NOTES:
 • ALL DIMENSIONS ARE IN mm
 • DIM 'D1' INDICATES THE DISTANCE REQUIRED TO REMOVE BACK PULL OUT ASSEMBLY.

IMPORTANT: THIS DRAWING IS THE PROPERTY OF Kirloskar Brothers Limited AND MUST NOT BE USED OR COPIED WITHOUT THEIR AUTHORITY IN WRITING.

A	F	H1	H2	B	C	M1	M2	N1	N2	S1	E1	S2	W	-	D
100	360	180	225	65.00	14.00	125	95.00	320	250	14.00	110	14.00	267	-	24.00

X	Y	L	D1	-	-	-	-	-	-	-	-	-	-	-	-
8.00	27.00	50.00	100	-	-	-	-	-	-	-	-	-	-	-	-

-	-	-	-	-	-	-	-	-	-	-	-	-	-	-	-
-	-	-	-	-	-	-	-	-	-	-	-	-	-	-	-

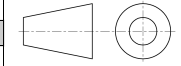

Kirloskar Brothers Limited
 KIRLOSKARVADI - 416308, DIST. - SANGLI (INDIA)

PUMP OUTLINE DRAWING

DRAWING NO. TL02-1-