

ECOL MOTOR
MODEL D1S 200L2-2
TECHNICAL DATA SHEET

General Data	
Frame size	200
Housing material	Casting iron
Install model	According to the standard
Type of feet	Removable feet (Standard) Fixed feet (Optional)
Net weight	230 kg
Insulation class	F (Standard)
	H (Optional)
Protection degree	IP 55 (Standard)
	IP 56 (Optional)
Thermal protection	Without (Standard)
	Customizable (Optional)
Rotation direction	Clockwise (Standard)
	Counter clockwise (Optional)
Service duty	S1
Vibration level	A
Balance	Half-key balanced
Cable glands	2 - M40x 1.5
Cooling	IC 411
Painting color	RAL 7024 (Standard)
	Customizable (Optional)
Regulations	IEC / DIN / ISO / VDE / EN
Standard	IEC 60034

Environmental conditions	
Ambient temperature	From -20°C to +40°C
Maximum altitude	1000 m above sea level

Electrical Data		
Output	37	kW
Frequency	50	Hz
Voltage (±5%)	400	V Δ @ 50Hz
	690	V Y @ 50Hz
	480	V Δ @ 60Hz
	828	V Y @ 60Hz
Rotation speed	2920	RPM @ 50Hz
	3504	RPM @ 60Hz
Rated current	65.8	A (In) @ Δ 50Hz
	37.99	A (In) @ Y 50Hz
Starting current	7.5	xIn
Rated torque	121.01	Nm (Mn)
Starting torque	2.2	xMn
	2.3	xMn
Efficiency	IE1	
	91.2	@ 100% load
	92.7	@ 75% load
Power factor cosφ	91.5	@ 50% load
	0.89	@ 100% load

Mechanical Data		
Bearings brand	C&U	(Standard)
	Customizable	(Optional)
Bearings type	6312 C3	(DE)
	6312 C3	(NDE)
Lifetime of bearings		- hours
Allowed radial load		3733 N
Allowed axial load		34700 N
Grease type	polyurea-based grease	
Lubrication interval of NDE bearing		8000 h
Lubrication interval of DE bearing		8000 h
Moment of inertia	0.173510	Kg*m ²
Noise level	92	dB(A)

Pump Performance Curve

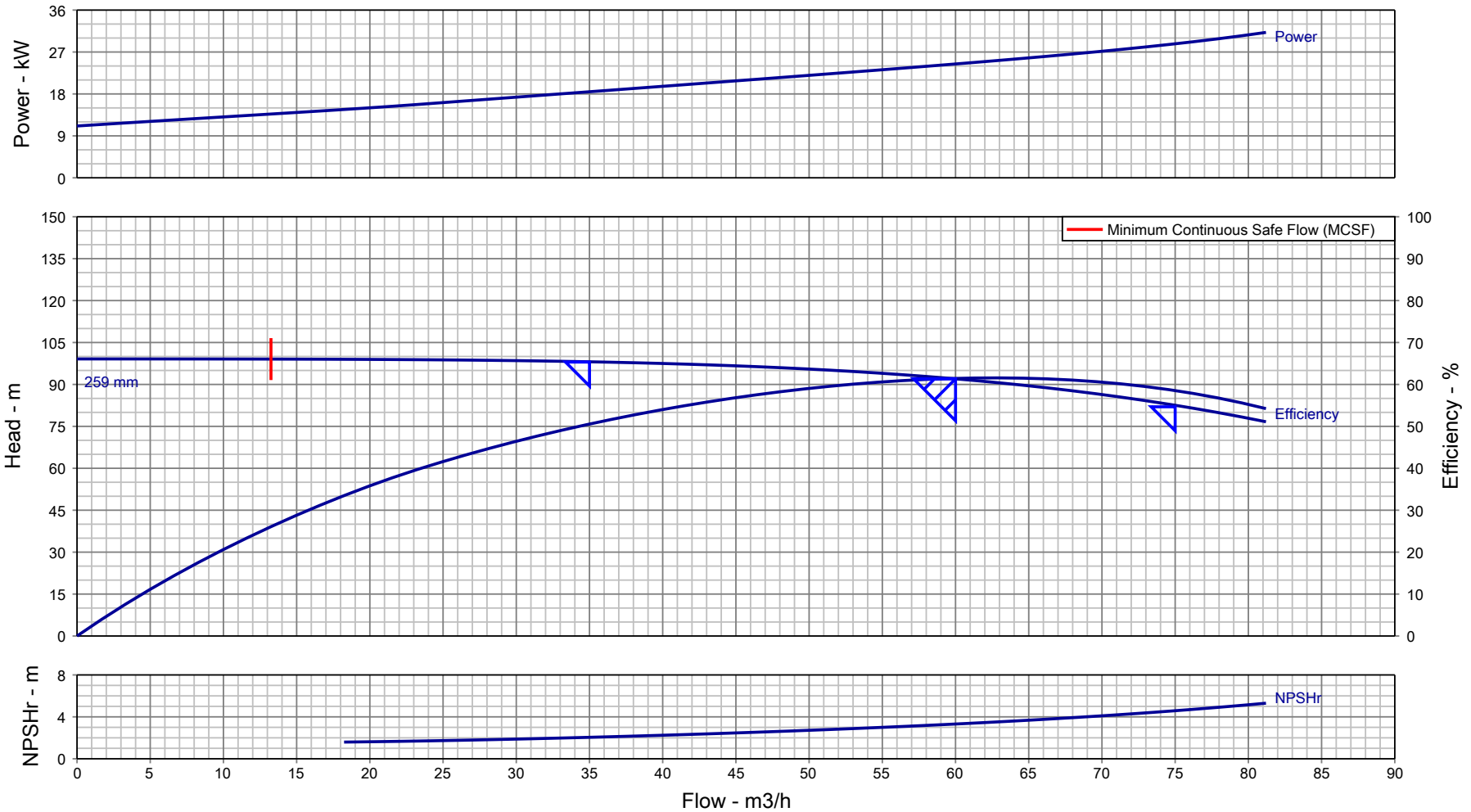

Customer :	Pump Size/ Stages : DB 50/26/ 1	Flow, rated : 60.00 m ³ /h
Customer enquiry :	Speed, rated : 2955 rpm	Differential Head : 92.00 m
Project : Default	Based on curve number : HD10212A0 Rev 0	Fluid density rated : 0.998 kg/dm ³
Quote number : 312657	Viscosity : 1.00 cSt	Efficiency : 61.44 %
Item number : 001	Cq/Ch/Ce/Cn [HI2010] : 1.00 / 1.00 / 1.00 / 1.00	Power, rated : 24.43 kW
Quantity : 1	Minimum recommended driver rating : 37.00 kW / 49.62 hp	NPSH required : 3.32 m
Date last saved : 08 Oct 2020 12:31 PM	Performance testing standard : ISO 9906 / ANSI-HI 14.6 Gr 2B	Liquid Type/ Application : Water

Notes: 1. Performance at shut off condition is approximate. 2. Rated impeller diameter is approximate. 3. Only duty point is guaranteed as per testing standard.



Enriching Lives

Pump Performance Datasheet

General			
Customer	:	Quote number	: 312657
Customer Enquiry No.	:	Pump model	: DB 50/26
Project	: Default	Stages	: 1
End user	: -	Based on curve number	: HD10212A0 Rev 0
Tag number	: 001	Date last updated	: 08 Oct 2020 12:31 PM
Service	: -	Quantity of pumps	: 1
Operating Conditions		Liquid	
Flow, rated	: 60.00 m3/h	Liquid handled	: Water
Suction pressure, rated / max	: 0.00 bar.g / 0.00 bar.g	Additional liquid description	: Fresh Water
Discharge pressure, rated	: 9.01 bar.g	Temperature, max	: 20.00 deg C
Head, rated (requested)	: 92.00 m	Solids diameter, max	: 0.00 mm
NPSH available, rated	: Value not specified	Solids in suspension by volume	: 0.00 %
Frequency	: 50 Hz	Specific gravity, rated / max	: 0.998 / 0.998 kg/dm3
		Viscosity, Rated / Max.	: 1.00 cSt / -
Performance		Driver & Power Data	
Pump speed, rated	: 2955 rpm	Driver sizing specification	: Maximum Power
Impeller Dia, Rated (Approx.)	: 259 mm	Margin over specification	: 0.00 %
Impeller diameter, maximum	: 264 mm	Power, rated	: 24.43 kW
Impeller diameter, minimum	: 205 mm	-	: -
Efficiency at duty point	: 61.44 %	-	: -
NPSH required / margin required	: 3.32 m / 0.50 m	Driver Rating	: 37KW
		Pressure Data	
MCSF	: 13.25 m3/h	Maximum working pressure	: 9.70 bar.g
Cq/Ch/Ce: [-]	: 1.00 / 1.00 / 1.00	Maximum allowable working pressure	: 16.00 bar.g
Water eq. duties (Qw/Hw/Ew)	: 60.00 m3/h / 92.00 m / 61.44 %	Maximum allowable suction pressure	: 1.96 bar.g
Suction / Delivery nozzle size	: 65.00 mm / 50.00 mm	Hydrostatic test pressure	: 18.34 bar.g
Noise level	: 90 dB		
		Construction	
Vibration level (RMS)	: 5.1 mm/s	Basic construction	: End Suction Pump-OH1
Test standard	: ISO 9906 / ANSI-HI 14.6 Gr 2B	Impeller type	: Enclosed
Starting condition	: Closed Delivery Valve	Selection status	: Acceptable
Material		Rec. Pipe Size (Suc / Del)	: 125 mm / 100 mm
MOC Code	: 16MOC		
Material (Casing / Impeller / Shaft)	: CI IS210:FG260 (012) / CI IS210:FG260 (012) / ST ST ASTM A276-410 ANLD (253)		
-	: -		

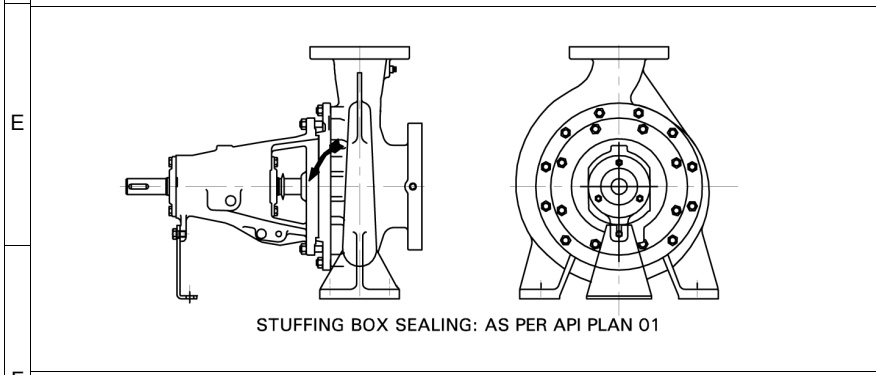
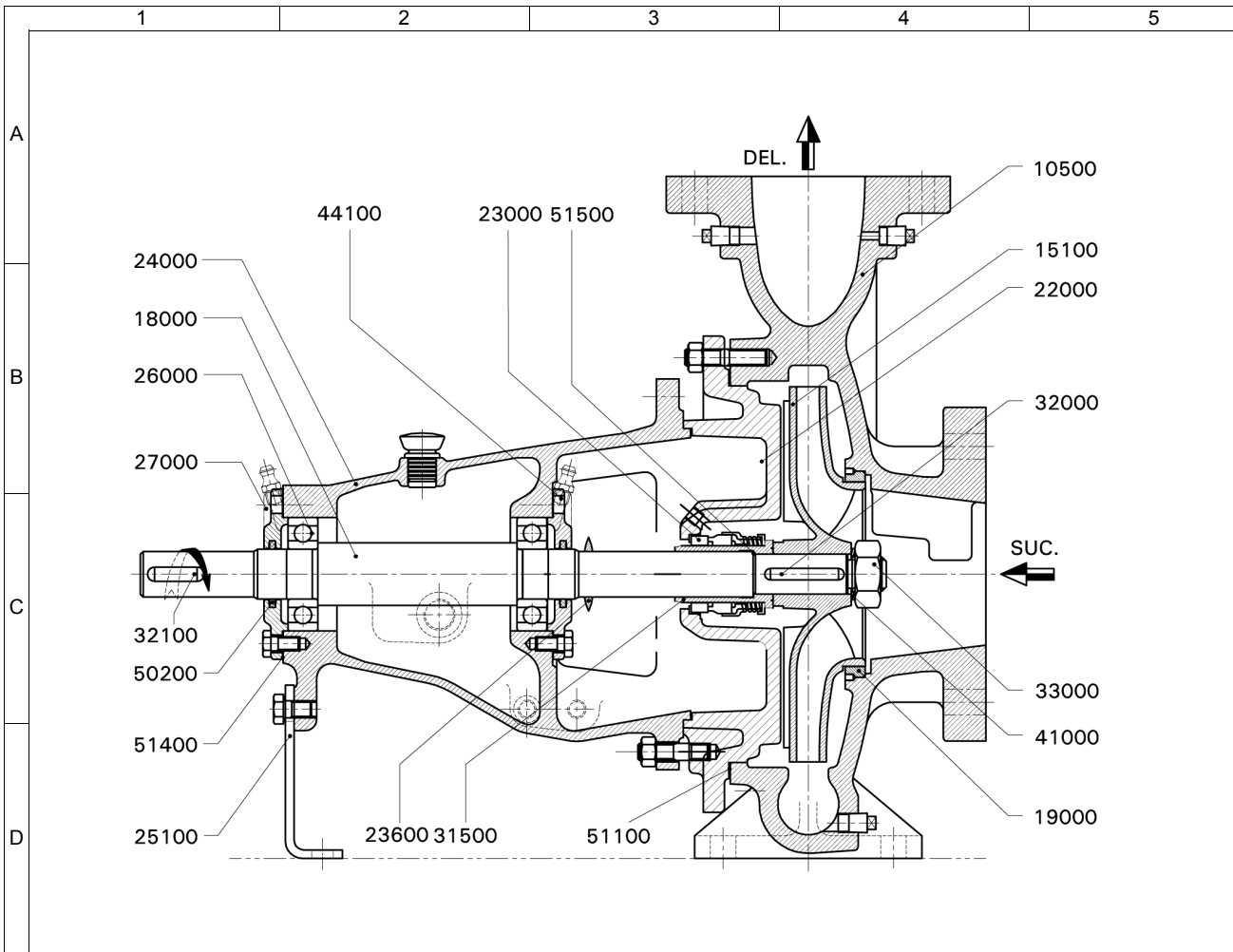

NOTES:

- " * " INDICATES RECOMMENDED SPARES.
- FASTENERS IN LIQUID CONTACT ARE IN CS

IMPORTANT: THIS DRAWING IS THE PROPERTY OF Kirloskar Brothers Limited. AND MUST NOT BE USED OR COPIED WITHOUT THEIR PRIOR AUTHORITY IN WRITING.



Enriching Lives

PART NO.	PART DESCRIPTION	MAT. CODE	MOC DESCRIPTION
10500	PUMP CASING	012	CI IS210:FG260
15100*	IMPELLER	012	CI IS210:FG260
18000*	PUMP SHAFT	253	ST ST ASTM A276-410 ANLD
19000*	WEAR RING - SUCTION SIDE	012	CI IS210:FG260
22000	CASING COVER	012	CI IS210:FG260
23000*	MECHANICAL SEAL	998	DIN SEAL
23600*	LIQUID DEFELCTOR	370	NATURAL RUB ASTM D2000AA-70SHORE/7MPa
24000	BEARING HOUSING	012	CI IS210:FG260
25100	SUPPORT FOOT	042	MS IS:5986-Fe410WA (OLD-IS:1079)
26000*	DEEP GROOVE BALL BEARING	000	STEEL
27000	BEARING COVER DE & NDE	012	CI IS 210-FG 260
31500*	SHAFT SLEEVE - MECHANICALSEAL	565	ST ST ASTMA276-410(210/250BHN)-ANLD
32000*	KEY FOR IMPELLER	253	ST ST ASTM A276-410 ANLD
32100	KEY FOR COUPLING	053	CS IS1570:40C8 HOT RLD
33001*	IMPELLER NUT	664	AUS ST ASTMA194/194M-8M-UNS S31600 (NUT)
41000*	LOCK WASHER-IMPELLER NUT	054	SPRING ST IS:4072-80C6
44100	GREASE NIPPLE	444	CS IS:1367 Part3 CL4.6 CDP
50200*	FELT RING	375	FELT
51100*	GASKET-CASING COVER	702	NON ASBESTOS FERROLITE NAM37 OR EQ
51400*	GASKET-BEARING COVER	702	NON ASBESTOS FERROLITE NAM37 OR EQ
51500*	GASKET-SHAFT SLEEVE	702	NON ASBESTOS FERROLITE NAM37 OR EQ

PUMP	DB 50/26	MOC	16
ENQUIRY NO./DATE	/	QUANTITY	1
PO. NO./DATE	-	TAG NO.	001
QUOTATION NO.	0	DATE.	-
O/A. NO.	-	MISI.	-
CUSTOMER	-		
END USER	-		
PROJECT	Default		
CONSULTANT	-		
SERVICE	-		

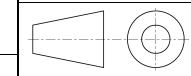

Kirloskar Brothers Limited
KIRLOS KARVADI - 416308, DIST.- SANGLI (INDIA)

CROSS SECTIONAL DRAWING

DRAWING NO. **TC02-1**

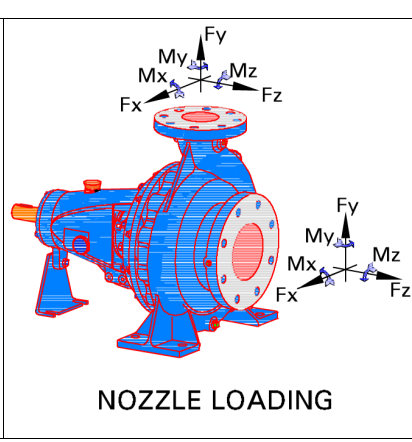
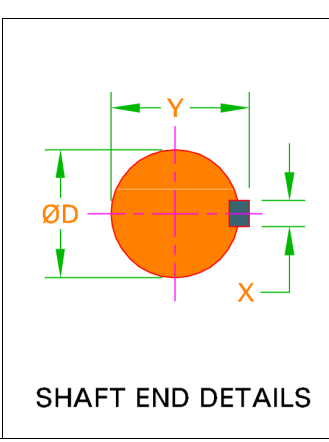
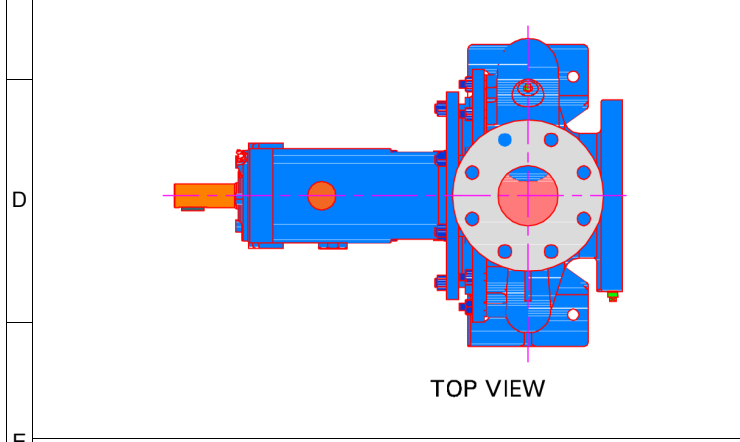
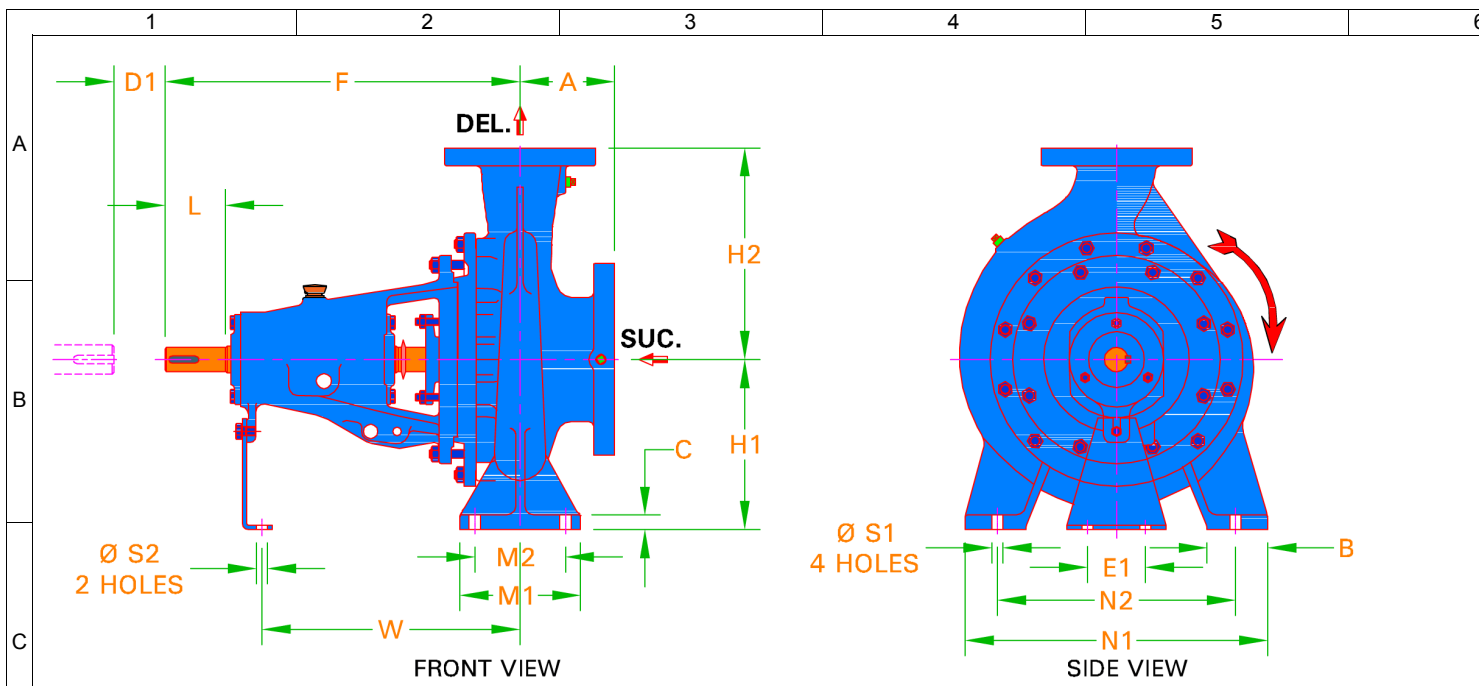

PUMP DUTIES			
CAPACITY	60.00 m ³ /h	EFFICIENCY	61.44 %
TOTAL HEAD	92.00 m	PUMP INPUT	24.43 kW
DENSITY	0.998 kg/dm ³	NPSHR	3.32 m

FLANGE DRILLING STANDARD AND DETAILS					
SUCTION	BS EN1092 PN16 FF		DELIVERY	BS EN1092 PN16	
	NOM. SIZE	RF DIA.	P.C.D.	NO OF HOLES	HOLE DIA.
SUCTION	65.00 mm	N.A.	145 mm	4	18.0
DELIVERY	50.00 mm	N.A.	125 mm	4	18.0

ALLOWABLE NOZZLE LOADING						
	FORCES			MOMENTS		
	Fx	Fy	Fz	Mx	My	Mz
SUCTION	57.00 kgf	142.0 kgf	114.0 kgf	843 N.m	422 N.m	422 N.m
DELIVERY	45.00 kgf	114.0 kgf	91.00 kgf	677 N.m	343 N.m	343 N.m

TAPPING DETAILS	
DESCRIPTION	SIZE / TYPE
Suction Gauge	1/4"BSP
Delivery Gauge	1/4"BSP
Casing Drain	3/8"BSP
Casing Vent	NA
Bearing Cooling in / out	NA
Pad Cooling in / out	NA
Priming in	NA
Base Drain	NA

DIRECTION OF ROTATION FROM DE		CLOCKWISE	
PUMP	DB 50/26	PUMP WT.	63.00
REC. DRIVER RATING	37KW	GD*2	0.02 kg
ENQ. NO./DATE	/	RATED SPEED	2955R
PO. NO./DATE	-	QUANTITY	1
QUOTATION NO.	0	TAG NO.	001
O/A NO.	-	DATE	-
CUSTOMER	-	MISI	-
END USER	-		
PROJECT	Default		
CONSULTANT	-		
SERVICE	-		

NOTES:
 • ALL DIMENSIONS ARE IN mm
 • DIM 'D1' INDICATES THE DISTANCE REQUIRED TO REMOVE BACK PULL OUT ASSEMBLY.

IMPORTANT: THIS DRAWING IS THE PROPERTY OF Kirloskar Brothers Limited AND MUST NOT BE USED OR COPIED WITHOUT THEIR AUTHORITY IN WRITING.

A	F	H1	H2	B	C	M1	M2	N1	N2	S1	E1	S2	W	-	D
100	360	180	225	65.00	14.00	125	95.00	320	250	14.00	110	14.00	267	-	24.00

X	Y	L	D1	-	-	-	-	-	-	-	-	-	-	-	-
8.00	27.00	50.00	100	-	-	-	-	-	-	-	-	-	-	-	-

-	-	-	-	-	-	-	-	-	-	-	-	-	-	-	-
-	-	-	-	-	-	-	-	-	-	-	-	-	-	-	-

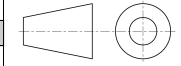

Kirloskar Brothers Limited
 KIRLOS KARVADI - 416308, DIST. - SANGLI (INDIA)

PUMP OUTLINE DRAWING