

DIESEL ENGINE

MODEL 4DSP-62

Performances

Ratings		3000 rpm	
		PRIME	STAND-BY
Rated Output	kWm	62	68

Note:

PRIME POWER: The prime power is the maximum power available with varying loads for an unlimited number of hours. The average power output during a 24h period of operation must not exceed 80% of the declared prime power between the prescribed maintenance intervals and at standard environmental conditions. A 10% overload is permissible for 1 hour every 12 hours of operation.

STAND-BY POWER: The stand-by power is the maximum power available for a period of 500 hours/year with a mean load factor of 90% of the declared stand-by power. No kind of overloads is permissible for this use.

Specifications

Mechanical system

Engine model	4DSP-62
Engine type	In-line, 4 stroke, water cooled
Combustion type	Direct Injection
Cylinder type	Dry liner
Air intake type	Turbocharger
Cylinder No.	4
Bore*Stroke(mm)	102*118
Total displacement(L)	3.857
Compression ratio	17.5:1
Firing order	1-3-4-2
Injection timing	15°±1°
Speed governor	Mechanical ≤8%
Exhaust temperature (°C)	≤550
Mean Effective Pressure (KPa)	780
Noise Level(dBA)	≤93
Exhaust gas back pressure(KPa)	5
Exhaust flow (m ³ /h)	995
Cooling air flow (m ³ /h)	550
Air for combustion flow (m ³ /h)	430
Piston Speed(m/s)	10.2
Dry weight (kg)	355
Dimension(L*W*H)(mm)	910*589*1145 (with radiator)
Rotation	Counter clockwise viewed from flywheel
Flywheel housing/flywheel	SAE4/ 7.5"

Mechanism

Type	Over head valve
Valves per cylinder	2
Valve lash(cold state)	Air intake valve 0.30-0.40mm Exhaust valve 0.30-0.40mm

Valve timing (crankshaft rotating angel)

Air intake valve open	24.5° before top dead center
Air intake valve close	55.5° after bottom dead center
Exhaust valve open	54° before bottom dead center
Exhaust valve close	26° after top dead center

Specific fuel consumption

rpm	3000
Fuel consumption (g/kWh)	≤230

Oil consumption

Oil consumption(g/kWh)	≤1.65
------------------------	-------

Fuel system

Fuel injector pump	BQ pump
Governor model	RSV full range type
Feed pump	Mechanical type
Injection nozzle	multi holes type
Fuel filter	Spin-on type
Fuel	Diesel

Lubrication system

Type	Mixed type, pressure and splash lubrication
Oil pump Displacement/speed (L/min/r/min)	Inner and outer rotor type 25/2000
Oil filter	Spin-on type
Lube oil total system capacity	9L including pipes, filters etc.

Cooling system

Cooling method	Water cooled, forced circulation
Coolant capacity: engine only	8L
Engine + radiator	15L
Water pump type	Centrifugal type driven by belt
Water pump capacity(L/min)	≥100
Thermostat	Opening temp.73°C
Cooling fan	Φ420mm, 7blades, PA

Electronic system

Charging alternator	14v/500w
AVR	Built-in type
Starting motor	12v/2.8kW
Battery capacity	12v/100Ah

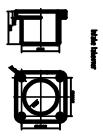
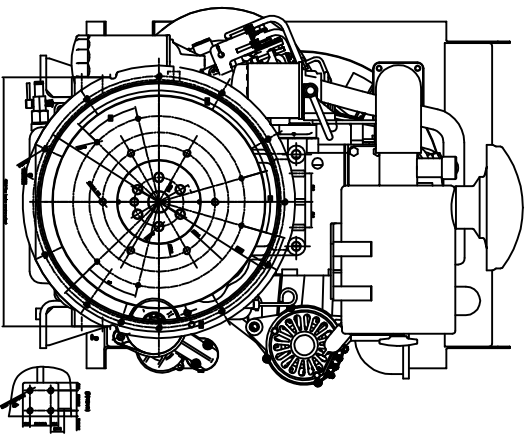
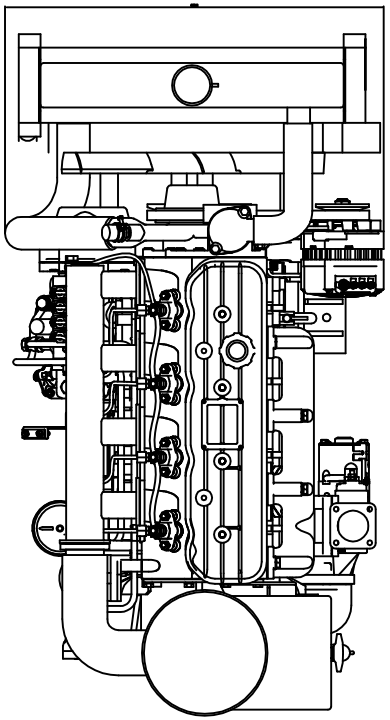
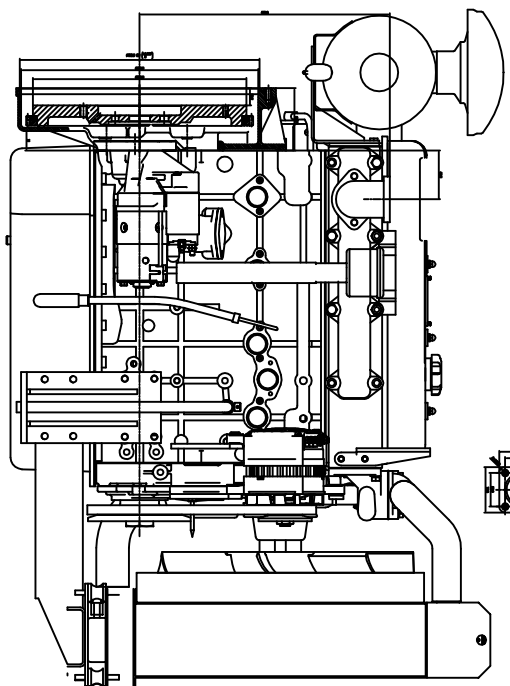
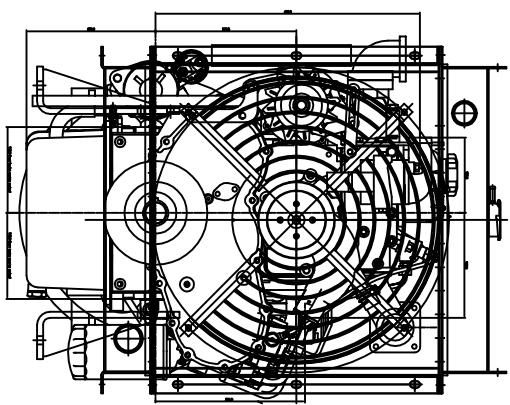
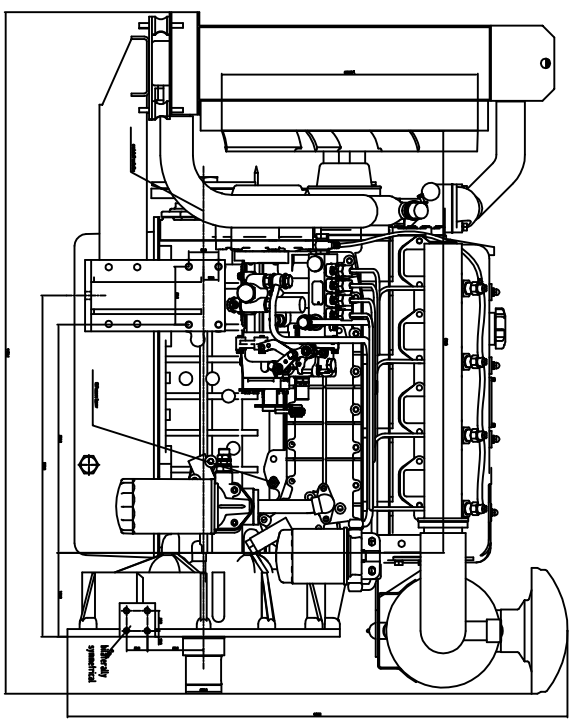

Engine model	4DSP-62
Engine type	In-line, vertical, four-stroke, water-cooled
Bore x stroke	102mmx118mm
Displacement	3.857L
Rated power/speed	62kW/3000r/min
Intake air preheating	Preheating in the glow plug cylinder
Electrical system voltage	12V
Number of teeth flywheel	126 teeth

CUSTOMER		TITLE	
-		DESSIN ENGINE ASSEMBLY	
SCALE		DATE	
1/5	14.6.24	DRAWN BY	
1/5	14.6.24	CHECKED BY	
-	-	APPROVAL NO.	
-	-	CONTRACT NO.	
-	-	REV. NO.	
-	-	JOB NO.	
-	-	4DSP-62	
REVISION		NO.	
1		20240514-01	