

DIESEL ENGINE

MODEL 6DSG-284

Performances

Ratings		1500 rpm		1800 rpm	
		PRIME	STAND-BY	PRIME	STAND-BY
Rated Output	kWm	258	284	258	284

Note:

PRIME POWER: The prime power is the maximum power available with varying loads for an unlimited number of hours. The average power output during a 24h period of operation must not exceed 80% of the declared prime power between the prescribed maintenance intervals and at standard environmental conditions. A 10% overload is permissible for 1 hour every 12 hours of operation.

STAND-BY POWER: The stand-by power is the maximum power available for a period of 500 hours/year with a mean load factor of 90% of the declared stand-by power. No kind of overloads is permissible for this use.

Specifications

Mechanical system

	6DSG-284 (50Hz)	6DSG-284 (60Hz)
Engine model	6DSG-284 (50Hz)	6DSG-284 (60Hz)
Engine type	In-line, 4 stroke, water cooled	
Combustion type	direct injection	
Cylinder type	Dry liner	
Air intake type	Turbocharger and intercooler	
Cylinder No.	6	
Bore*Stroke(mm)	126*130	
Total displacement(L)	9.726	
Compression ratio	16:1	
Firing order	1-5-3-6-2-4	
Injection timing	14°±1°	16°±1°
Speed governor	Electronic governor, ≤1%	
Exhaust temperature (°C)	≤600	
Mean Effective Pressure (KPa)	2122	1768
Noise Level(dBA)	≤105	
Exhaust gas back pressure(KPa)	5	
Exhaust flow (kg/h)	1250	1312
Cooling air flow (m³/s)	4.54	5.54
Air for combustion flow (m³/h)	1012	1076
Piston Speed(m/s)	6.5	7.8
Dry weight (kg)	950	
Dimension(L*W*H)(mm)	2230*780*1539(with radiator)	
Rotation	Counter clockwise viewed from flywheel	
Flywheel housing/flywheel	SAE1/ 14"	

Mechanism

Type	Over head valve
Valves per cylinder	2
Valve lash(cold state)	Air intake valve 0.30mm Exhaust valve 0.40mm

Valve timing (crankshaft rotating angel)

Air intake valve open	34°-39° before top dead center
Air intake valve close	61°-67° after bottom dead center
Exhaust valve open	76°-81° before bottom dead center
Exhaust valve close	26°-34° after top dead center

Specific fuel consumption

rpm	1500	1800
Fuel consumption (g/kWh)	≤210	

Oil consumption

Oil consumption(g/kWh)	≤0.816
------------------------	--------

Fuel system

Fuel injector pump	In-line "PW" type
Governor model	RSV full range type
Feed pump	Mechanical type
Injection nozzle	DELPHI brand, multi hole type
Fuel filter	Fleetguard brand Double and spin-on type/water separator
Fuel	Diesel

Lubrication system

Type	Fully forced pressure feed type
Oil pump Displacement/speed (L/min/r/min)	Single grade gear type 144/2241
Oil filter	Spin-on type
Lube oil total system capacity	23L including pipes, filters etc.

Cooling system

Cooling method	Water cooled, forced circulation
Coolant capacity: engine only	14L
engine+radiator	38L
Water pump type	Centrifugal type driven by belt
Water pump capacity(L/min)	2500r/min, ≥383
Thermostat	Opening temp.71±2℃ full open temp.82℃
Cooling fan	Φ 760m, 9 blades, PA

Electronic system

Charging alternator	28v/1000w
AVR	Built-in type brushless
Starting motor	24v/8.1kW brushless
Battery capacity	2pcs 12v/185Ah

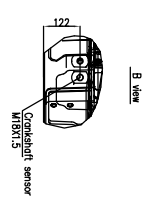
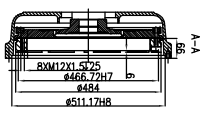
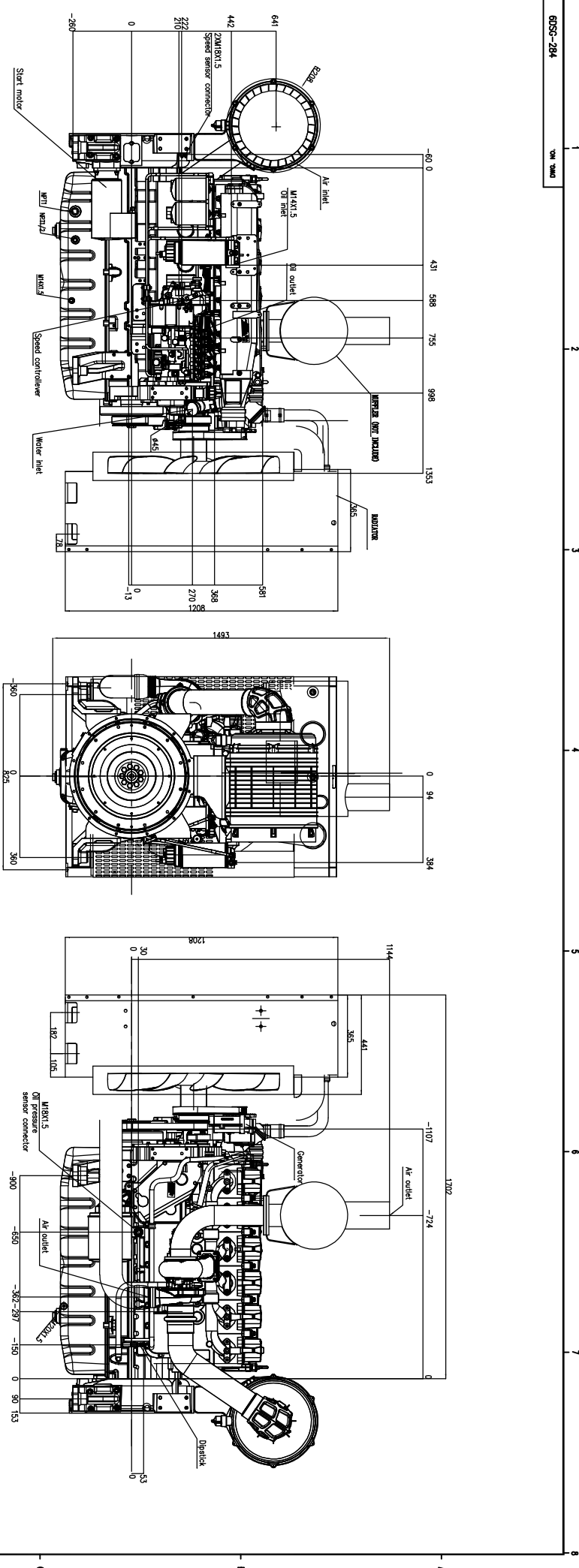

CUSTOMER		TITLE	
-		DESSIN ENGINE ASSEMBLY	
SCALE		DATE	
1/5	18/09/20		
APPROVAL	APPROVAL		
CONTRACT NO.	CONTRACT NO.		
60SC-284	60SC-284		
REVISED	REVISED		
03	03		