

DIESEL ENGINE

KDG SERIES FOR GENERATOR

Model: 6KDG-180	Prime power	160.0KW(217.5HP)/1500 rpm	172.0KW(234.0HP)/1800 rpm
	Standby Power	180.0KW(245.0HP)/1500 rpm	190.0KW(258.0HP)/1800 rpm

- The engine performance is as per ISO 3046. Type of operation is based on ISO 8528.
- Prime power is available for an unlimited number of hours per year in a variable load application.
- The permissible average power output over 24 hours of operation shall not exceed 80% of the prime power rating.

Engine Specifications

In-Line, 4 stroke, water-cooled, Turbocharged	
Combustion type	Direct injection
Cylinders - Bore x stroke	6 - 114 x 135 mm
Displacement	8268 cc
Firing order	1-5-3-6-2-4
Compression ratio	18 : 1
Dry weight	Approx. 750 kg
Dimension(LxWxH)	1460 x 765 x 1275 mm
Rotation	Anti-clockwise
Flywheel / Housing	SAE # 11.5 / # 3

Fuel System

Injection pump	Direct Injection type
Governor	Electronic type
Feed pump	Mechanical type
Injection nozzle	Multi-hole type/ 0.255 mm
Opening pressure	25+0.5MPa
Fuel filter	Single Stage, Paper

Fuel Consumption

Prime power at 1500rpm	40.6 liters/h
Standby power at 1500rpm	44.7 liters/h
Prime power at 1800rpm	43.3 liters/h
Standby power at 1800rpm	47.6 liters/h

Cooling System

Cooling method	Fresh water forced type
Water pump	Centrifugal, Belt driven
Water Capacity	15.0 liters (engine only)
Max. water Temp	95 degree C.
Cooling Fan	Blade 7EA - Ø 560 mm

Lubrication System

Lub. Oil Pan Capacity	16.0 liters
Max. allowable Oil Temp	120 degree C.
Oil pressure	Min. 294 kPa Max. 490 kPa

Intake & Exhaust System

Max air restriction	Clean 2 kPa / Dirty 5 kPa
Exhaust back	Max 6 kPa

Engineering Data

Combustion Air at 1500rpm	33.75 m3/min
Exhaust Gas at 1500rpm	41.25 m3/min
Combustion Air at 1800rpm	42.92 m3/min
Exhaust Gas at 1800rpm	55.79 m3/min

Electric System

Charging generator	27.5 V x 55 A
Starting motor	24 V x 7.5 kW
Battery	12 V x 2 x 120 Ah

Conversion Table

PS = kW x 1.3596	in. = mm x 0.0394
psi = kg/cm ² x 14.2233	
HP= PS x 0.98635	

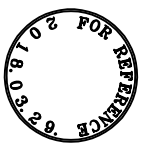
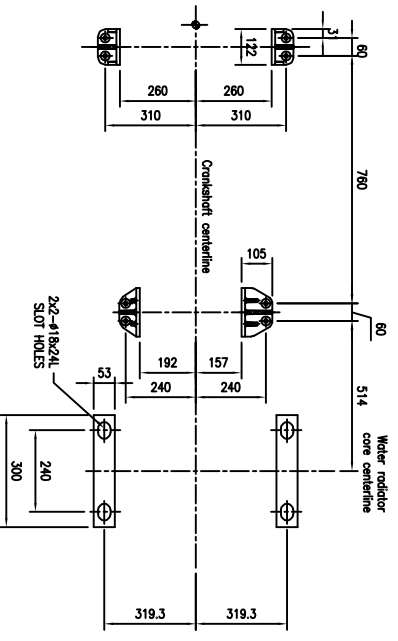
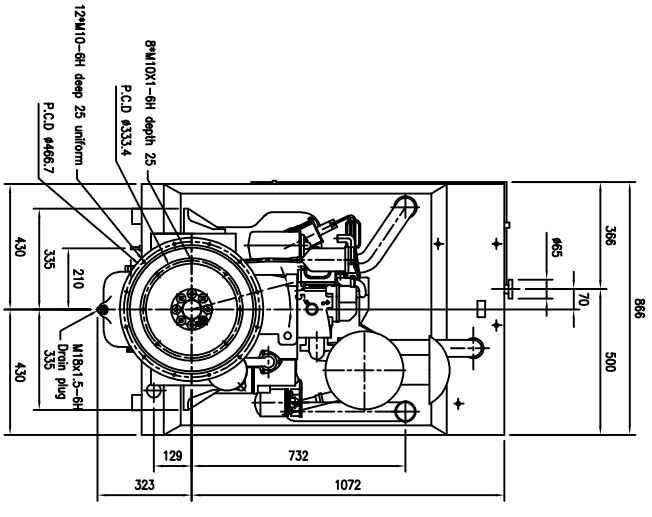
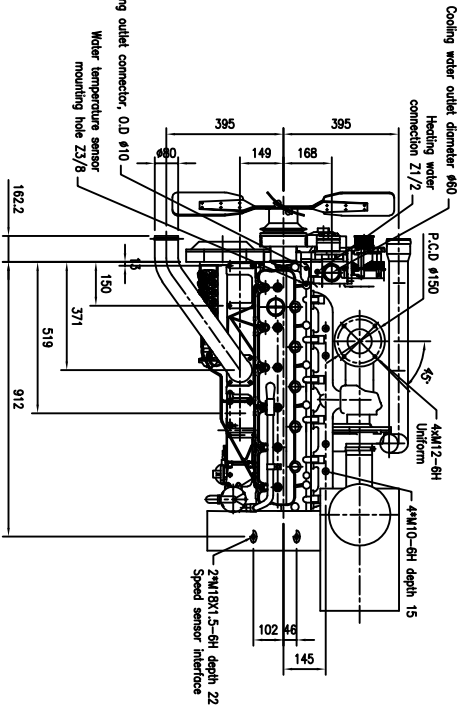
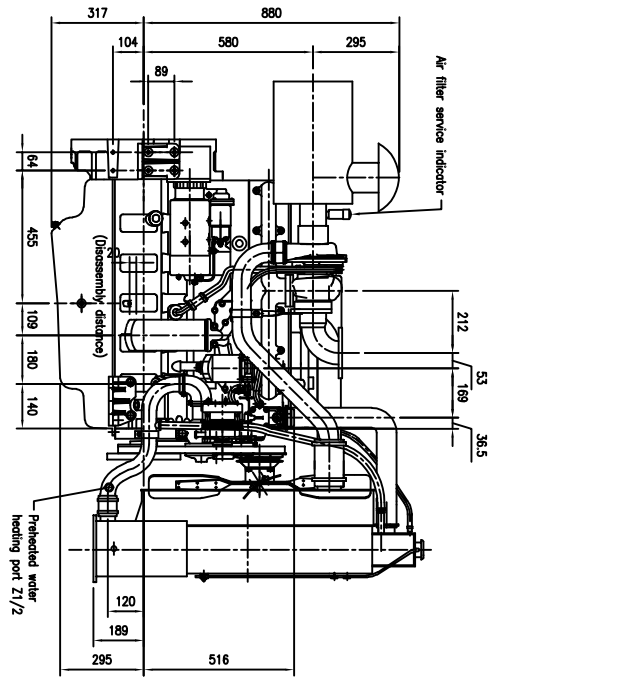
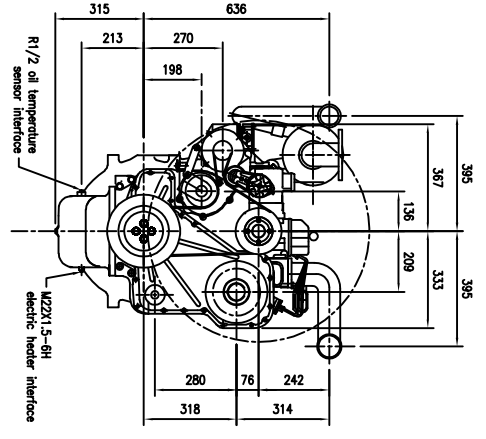
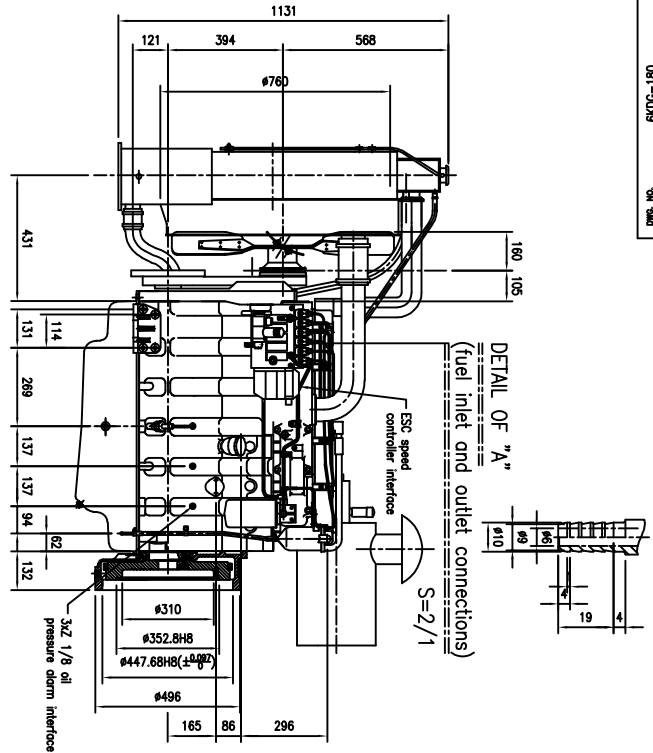

DETAIL OF FLYWHEEL HOUSING

SCALE = 2/1
FLYWHEEL : SAE#11.5
FLYWHEEL HOUSING : SAE#2

REV.	NO.	DESCRIPTION	DATE	BY	CHKD.	APP.	CLIENT	REV.
1								
2								
3								
4								
5								
6								
7								

CUSTOMER		TITLE	
E. N. G.		KODOC ENGINE ASSEMBLY	
SCALE	DATE	DATE	DATE
1/20	18.03.29		
DESIGN	CHKD.	APP.	REV.
CONTRACT	COMMITTEE	REV. NO.	REV. NO.
		8100-180	
JOB NO.	REV. NO.		
201333-411			