

ECOL MOTOR
MODEL D1S 280M-2
TECHNICAL DATA SHEET

General Data	
Frame size	280
Housing material	Casting iron
Install model	According to the standard
Type of feet	Removable feet (Standard) Fixed feet (Optional)
Net weight	572 kg
Insulation class	F (Standard)
	H (Optional)
Protection degree	IP 55 (Standard)
	IP 56 (Optional)
Thermal protection	Without (Standard)
	Customizable (Optional)
Service duty	S1
Vibration level	A
Balance	Half-key balanced
Cable glands	2 - M50x 1.5
Cooling	IC 411
Painting color	RAL 7024 (Standard)
	Customizable (Optional)
Regulations	IEC / DIN / ISO / VDE / EN
Standard	IEC 60034

Environmental conditions	
Ambient temperature	From -20°C to +40°C
Maximum altitude	1000 m above sea level

Electrical Data		
Output	90	kW
Frequency	50	Hz
Voltage (±5%)	400	V Δ @ 50Hz
	690	V Y @ 50Hz
	480	V Δ @ 60Hz
	828	V Y @ 60Hz
Rotation speed	2930	RPM @ 50Hz
	3516	RPM @ 60Hz
Rated current	155.2	A (In) @ Δ 50Hz
	89.6	A (In) @ Y 50Hz
Starting current	7.5	xIn
Rated torque	293.34	Nm (Mn)
Starting torque	2	xMn
Breakdown torque	2.3	xMn
		IE1
Efficiency	93	@ 100% load
	92.8	@ 75% load
	90.9	@ 50% load
Power factor cosφ	0.9	@ 100% load

Mechanical Data		
Bearings brand	C&U	(Standard)
	Customizable	(Optional)
Bearings type	6319 C3	(DE)
	6319 C3	(NDE)
Lifetime of bearings		- hours
Allowed radial load		6750 N
Allowed axial load		57700 N
Grease type	polyurea-based grease	
Lubrication interval of NDE bearing		3500 h
Lubrication interval of DE bearing		3500 h
Moment of inertia	0.795390	Kg*m ²
Noise level	94	dB(A)

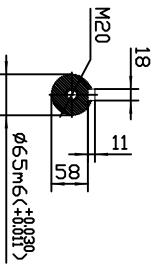
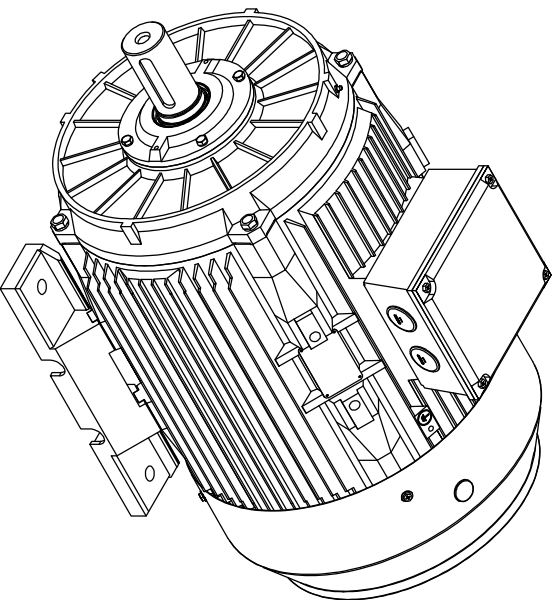
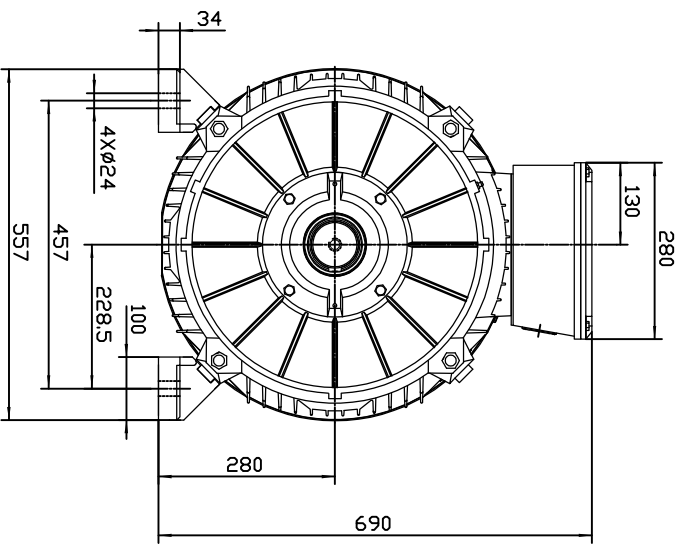
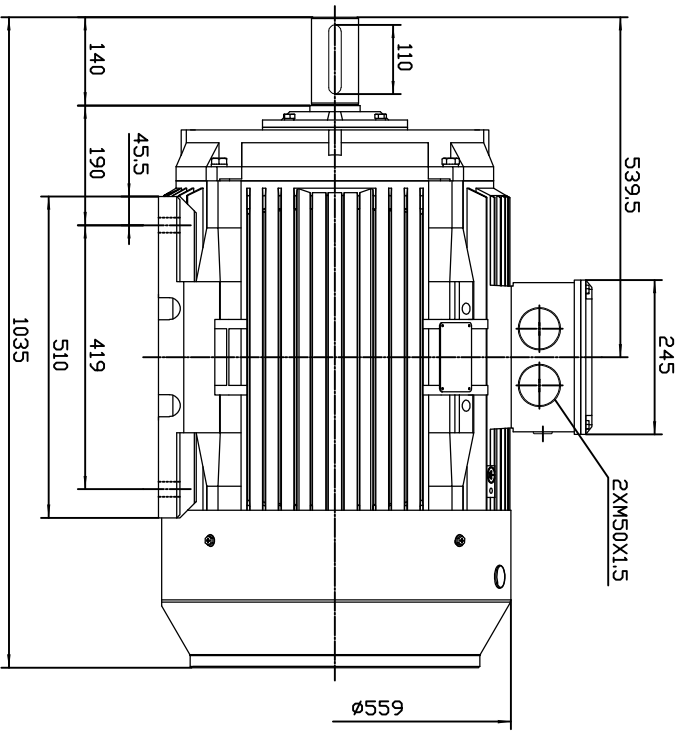

DS 280M-2P B3

DS 280M-2P B3 MOUNT		1HMV.010.1095B	
DESSUN MOTOR DIS SERIES		RATE 1:6	
REVISION			